

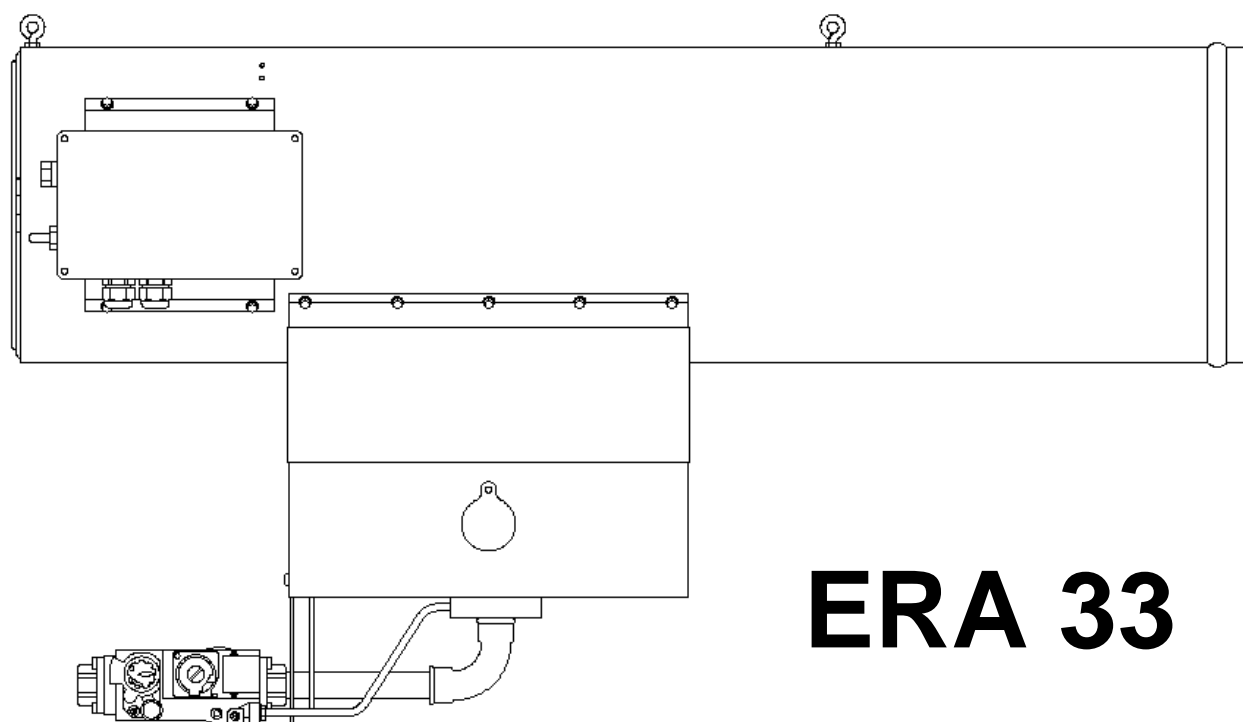

**USER MANUAL
AND
INSTALLATION INSTRUCTIONS**



ERA 33

NATURAL GAS
PROPANE



2014

Congratulations on your purchase!

We're sure you'll be very happy with your new **ERMAF**

ERA 33 Heater

Declaration of conformity



We, the manufacturer, hereby declare that the product GP complies with the requirements of the listed Directives and Standards.

Directives:

- 2009/142/EC
- 2004/108/EC
- 2006/42/EC
- 2006/95/EC

Standards:

- DIN 3362, EN 298
- EN 60730
- EN 1643, EN 525:2009

The relevant product corresponds to the type tested by the notified body 0085.

The production is subject to the surveillance procedure pursuant to Directive 2009/142/EC according to annex II paragraph 3.

Elster-Instromet B.V.

Scan of the Declaration of conformity (D, GB) – see www.docuthek.com

NOTE

In order to ensure that your new equipment will always work properly and efficiently and to ensure your personal safety, we would ask you the following:

Please read through this User Manual thoroughly and take particular note of the warning and safety instructions before starting up the machine for the first time.



Table of contents

1. General information	2
1.1. Symbols.....	2
1.2. Special safety instructions.....	2
1.3. General safety regulations	2
1.4. Electrical equipment.....	3
1.5. Maintenance.....	3
1.6. Ordering spare parts	3
1.7. Liability	3
1.8. Interruptions due to power failures.....	4
1.9. First Aid	4
1.10. Disposal.....	4
2. Introduction	5
2.1. Equipment description.....	5
2.2. Special safety regulations	5
3. Technical data	6
4. Installation instructions	7
4.1. Positioning.....	7
4.2. Installation	7
4.3. Connecting to gas	8
4.4. Connecting to mains.....	9
4.5. Thermostat control/climate computer.....	9
5. Operating instructions	10
5.1. Commissioning.....	10
5.2. Heating / Ventilating	10
6. Maintenance	11
7. Malfunctions	12
8. Spare parts	13
8.1. Diagram for ERA 33 parts list.....	13
8.2. ERA 33 parts list.....	14
8.3. Drawing switching cabinet (parts list).....	15
8.4. Parts list switching cabinet	15
9. Appendices	16
9.1. Burner pressure table.....	16
9.2. ERA 33 circuit drawing	17
9.3. Gas connection drawing.....	18
9.4. Return of goods form	19
9.5. Contact	19



1. General Information

1.1. Symbols

You will see the following symbols when you read through the User Manual:

	Warning of a general danger
	Warning of dangerous voltage
	Wear protective gloves

1.2. Special safety instructions

	CAUTION	This indicates risks or unsafe processes which can easily cause slight injury or damage to property.
	NOTE	This provides information on how to handle the equipment effectively, economically and in an environmentally sound manner.

1.3. General safety regulations

ERMAF equipment may only be used for the purpose for which it is intended.

Use of the equipment for any other purpose shall be regarded as improper use. The manufacturer will not be liable for any damage resulting from improper use; the user shall bear the sole risk thereof.

Proper use of the equipment also entails observing the manufacturer's conditions of operation, maintenance and installation.

Currently applicable accident prevention regulations and all other generally recognised rules of occupational medicine and safety must be observed.

Check all safety and operational equipment

- before starting up
- at reasonable intervals
- after any modifications or maintenance work

to ensure that it is safe and fully operational.

The regulations of the electricity supply company must be observed.

1.4. Electrical equipment

- Any work extending beyond the scope of equipment maintenance must be performed by a specialist only.
- Always disconnect the appliance from the mains before performing any work on it.
- Before starting up the appliance, examine all electrical wiring for any visible defects. Change any damaged wiring before switching on the appliance.
- Have any plug devices that are damaged or destroyed replaced by a qualified electrician.
- Do not pull the plug out of the socket by the flex.
- Covering electric motors can cause high temperatures to build up, which can destroy the electrical equipment and cause fires.

1.5. Maintenance



Always disconnect the appliance from the mains before working on the electrical equipment!

Repairs should only be carried out by persons who have the training, knowledge or practical experience to ensure that the repair is done properly.

Maintenance, repair and cleaning work should only be carried out with the drive switched off and the motor idle. The same applies to the rectification of functional defects.



Wear protective gloves if there is a danger of injuring your hands!

The user must satisfy himself that the appliance or machine has been returned to its proper state after carrying out repair work. Technical equipment must not be re-started until all safety devices are in place.

Spare parts must as a very minimum correspond to the technical requirements specified by the manufacturer of the equipment. This will be the case if, for example, original spares are used.

1.6. Ordering spare parts

When ordering spare parts, always indicate the following:

- Code no. and description of part or item number with description and manual number for uncoded parts;
- Number of original invoice;
- Electricity supply, e.g. 230/400 V, 3 ph, 50 Hz.

1.7. Liability

Any unlawful alterations to the machine or the software will rule out manufacturer liability for any resultant damage.

1.8. Interruptions

We recommend installing warning systems to monitor your operating equipment. This will protect your animals or plants and consequently your economic existence.

In the case of a power failure, the emergency power unit should automatically switch on.

Power units with cardan transmission for attachment to tractors are also suitable for use as emergency power units. Please consult your property insurance company for more information.

1.9. First Aid

Unless explicitly specified otherwise, there should always be a first aid box at the workplace in case of accidents. Any material removed from the first aid box must be replaced immediately.

If you ask for help, always provide the following information:

- where the accident happened;
- what happened;
- how many persons injured;
- what the risk of injury is;
- who is reporting the accident!

1.10. Disposal

After installation or repairs on the installation, the packaging and non-usable waste should be delivered to the appropriate places.

The contents of this manual are liable to change without notice.

If you discover any errors or inaccurate information, we would be grateful if you could inform us of these.

All trademarks named or depicted in the text are trademarks of their respective holders and are recognized as protected.

© Copyright 2004 by **ERMAF**

2. Introduction

2.1. Equipment description

ERMAF air heaters are ideal for heating and/or CO₂ enrichment in greenhouses and plastic tunnels. The heaters are also excellent for heating sheds or pig sties, or for heating or frost protection in areas used for the storage and/or preservation of potatoes, tuberous crops and the like.

Particularly in their initial stages of life, young animals need a lot of heat, no matter Optimum temperatures right from the start have a decisive impact on their development, health and general performance.

ERMAF's ERA 33 creates the right conditions for your rooms. This heater is available for use with natural gas or propane. Later conversion from natural gas to propane or vice versa is no problem. No chimney is needed. The ERA 33 is installed exactly where it will be most effective in generating heat. 100% of the heat it produces will benefit your rooms - so there is no heat loss.

Another positive feature is that the "open combustion" system increases the relative humidity in the room.

The ERA 33 is controlled by thermostat or by computer; it also has pilot flame control. If for some reason the appliance does not ignite or the flame is extinguished, the gas supply is immediately cut off. A solenoid valve in the compact unit ensures high levels of safety. No unburnt gas can escape.

2.2. Special safety regulations

	The ERA 33 is a heater for use in the mentioned rooms *. Use of the equipment for any other purpose shall be regarded as improper use. The manufacturer will not be liable for any damage resulting from improper use; the user shall bear the sole risk thereof.
---	---

* The heater is not suited for use in poultry-sheds because of dust.

	<p>With storing manure, gases are formed which are partly dissolved. These poisonous and explosive gases (e.g. sulphurhydrogen and methane) can be released during stirring and rinsing.</p> <p>With a source of ignition a big explosion may occur.</p> <p>To prevent a hazardous situation shut off the heaters completely before stirring or rinsing.</p> <p>Also observe the following points:</p> <ul style="list-style-type: none"> • Close the doors when manure is stored outside. • Ventilate the room thoroughly.
---	---

Notice:

No account is taken with general hazard of fire in this manual. Consult your fire insurance company and/ or your local fire brigade for more information.

3. Technical Data

Output :33 kW

Gas consumption

- Natural gas : low-grade gas3,5 m³/ h
 high-grade gas3,0 m³/ h
 - Propane :2,4 kg/ h

Inlet pressure

- Natural gas :20 - 25 mbar
 - Propane :50 mbar

Burner pressure

- Natural gas : (injector 16 x Ø 1,25)See table Chapter 9.1
 - Propane : (injector 16 x Ø 0,75)29 mbar

Maximum line pressure 60 mbar

Gas supply :1/2"

Air circulation:

- Ventilation :± 1.300 m³/ h
 - Heating :± 1.700 m³/ h

Mains power supply:230 V/ 50 Hz / 150 W

Safety device in event of lack of air:.....micro-switch

Flame control :Max. thermostat

Pilot flame control:.....Thermo couple

Projection :30 m

Length :1.000 mm

Width :351 mm

Height :584 mm

Weight :17 kg

The ERA 33 consists of **4 main components**:

1. Shell : used for air supply;
2. Combustion chamber : the gas/air mixture is burned in this chamber.
3. Ventilator : this conveys the hot air into the room, supplies the air needed for combustion and the air for cooling the combustion chamber and the flue gases;
4. Switchcupboard : this contains the regulation and safety apparatus.

Description of materials:

Shell : high-grade 430 steel

Burner chamber : high-grade 430 steel

The materials used are capable of withstanding maximum loads.

4. Installation Instructions

4.1. Positioning

The number of heaters required depends on the size and nature of the rooms, the required temperature and the relevant climate zone.

4.2. Installation

	CAUTION	The following points must be observed!
---	----------------	--

- The appliance must be placed on a horizontal surface or suspended by means of the three chains supplied.

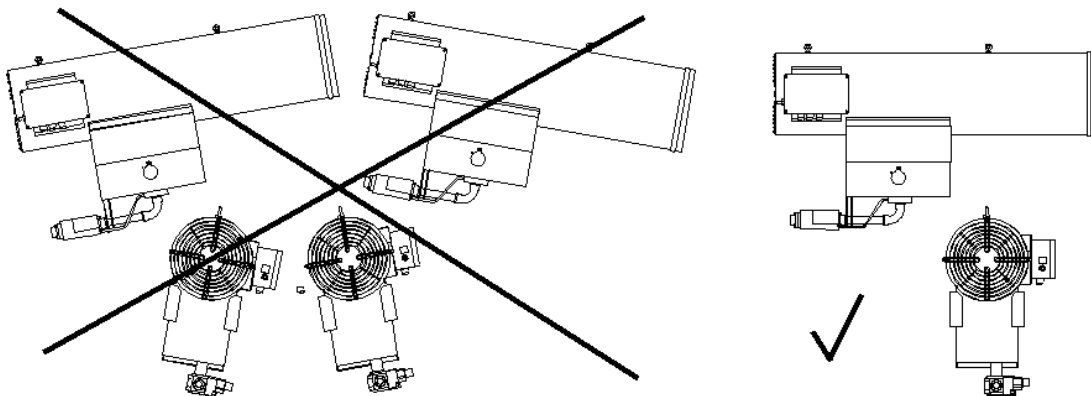

- Keep obstacles away from inlet or outlet of the heater.
- The heater must not point towards a wall made of flammable material if it is less than 2 meters away from the wall.
- The suction end of the heater must be at least 1 meter away from the wall.
- The heater must not be connected to or inside closed duct/pipe systems.
- Local regulations must be observed for the electricity and gas supplies.
- The room in which the appliances are installed must either have a mechanical extractor device or ventilation system that extracts at least 100 m³ of air per hour for every 10 kW of installed output, or it must have adequate natural ventilation.
- If the room has two openings, a ventilation factor of 1.0 (i.e. one change of room air per hour) can be achieved naturally providing these openings have a free opening area of at least 60 x B cm², where B is the installed output in kW.
- The overall output of the installed appliances must not exceed 10 kW per 200 m³ of room volume if natural ventilation is used.

4.3. Connecting to gas

	CAUTION	Regional gas type and quality must be taken into account!
---	----------------	---

There is a 1/2" gas connection at the side of the appliance.

The ERA 33 must only be connected to the local gas supply by authorized personnel and with approved connection materials (see Appendix: Gas connection diagram).

Natural gas:

Inlet pressure:	20 - 25 mbar
Injector:	16 x ø 1,25
Burner pressure: high/low-caloric gas:	See table Chapter 9.1
Gas consumption: high-caloric gas:	± 3,0 m ³ /h
Gas consumption: low-caloric gas :	± 3,5 m ³ /h
Pilot flame injector:	0,53 x 0,28 mm

Propane:

Inlet pressure:	50 mbar
Injector:	16 x ø 0,75
Burner pressure:	29 mbar
Gas consumption:	± 2,4 kg/h
Pilot flame injector:	ø 0,28 mm

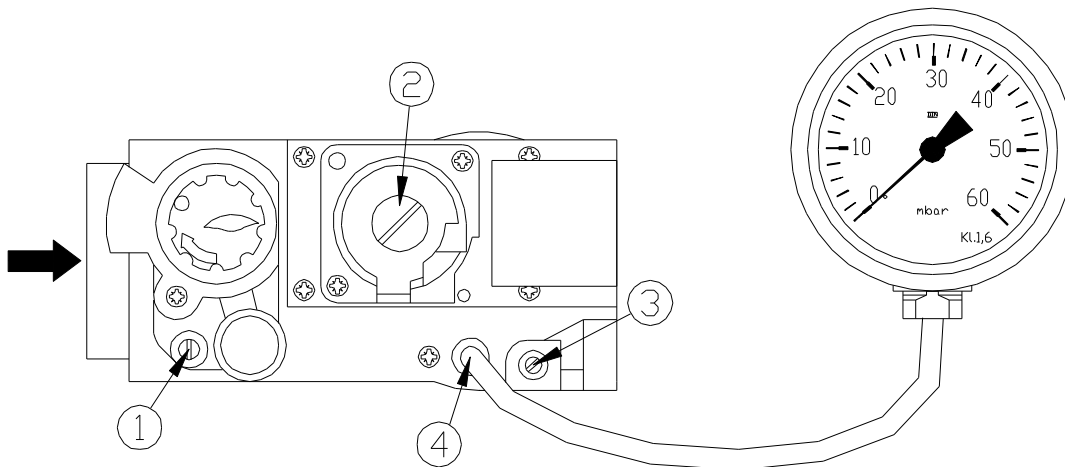

1. Inlet pressure tap
2. Pressure flow adjustment
3. Pilot flow adjustment
4. Outlet pressure tap

General:

- Use the table in the appendix (Chapter 9.1) to set the burner pressure.
- The burner pressure must be measured and set when the appliances are started up for the first time.
- Local authority and electricity supply company regulations must be observed.

Conversion

Conversion to another type of gas must be carried out by your gas fitter. For conversion from natural gas to liquid gas and vice versa, the 16 injectors and pilot flame injector need to be replaced and the burner pressure adjusted.

4.4. Connecting to mains

Local authority and electricity supply company regulations must be observed.

Connection values: 230V/ 50Hz/ 120W

The heater is connected with the 230V plug.

4.5. Thermostat control/climate computer

The appliance can be run automatically. To do this, connect the thermostat to terminals 11 and 12 (see appendix 9.2: Circuit diagram). If using an shed-thermostat, note that the voltage is 230 V.

	CAUTION	Every appliance must be connected to a separate thermostat.
---	----------------	---

If you wish to connect more than one appliance to a thermostat or climate computer, each appliance must be activated by means of a voltage-free contact. This work may only be carried out by authorized personnel.

A possibility is:

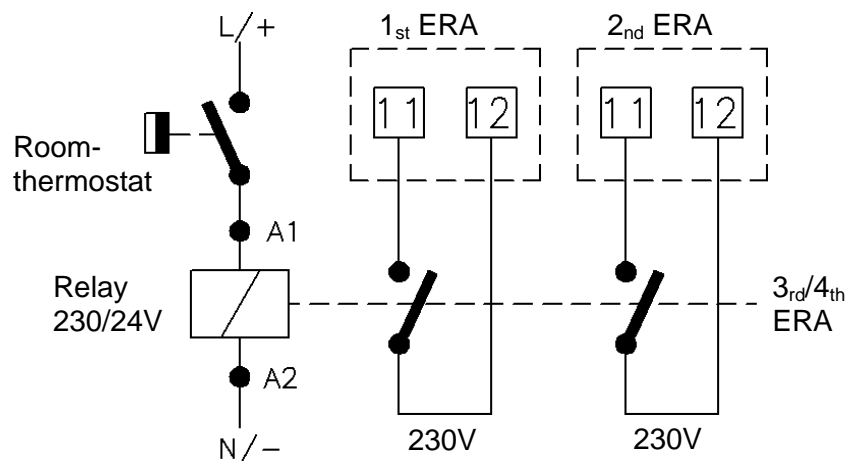

5. Operating instructions

5.1. Commissioning

First check that the appliance is connected to the mains and then open the gas tap.

Lighting Procedure:

1. Depress knob and hold it down
2. Ignite pilot burner (with match)
3. When pilot burner has been lit, hold knob down for 20 seconds
4. Release knob
5. If pilot flame is not established, wait 3 minutes before making another attempt to light pilot burner.

To start up the heater, switch to "heating"

Switch on the thermostat / climate computer or timer.

5.2. Heating / ventilating

The appliance can be used for heating or ventilating.

There is a 3-position switch for switching between "Ventilate / Off / Heating" operation on the water-resistant switch cupboard.

After switching on, the ventilator is turning on right away.

When the switch is in the "Heating" position, the ventilator will start to rotate, the gas valve opens, the gas ignites, forming the main flame straight away.

The thermo couple will ensure that the pilot flame is burning properly. If it is not, the compact unit will switch off the gas supply.

The vane switch will ensure that the ventilator is turning. Only then the gas valve can be opened.

When the switch is in the "Ventilate" position, the ventilator will start to rotate but the gas valve will not be opened.

6. Maintenance



Do not use water to clean the appliance!
Inadequate cleaning can result in damage by fire.

Have your appliances checked and adjusted by a recognized gas fitter at least once a year. The appliance must be thoroughly cleaned of dust at regular intervals and after every throughput. Do not use water. Clean with a compressor.

Clean the appliance with compressed air before every use.

Method:

- Clean the burner with compressed air from the underside.
- If the burner is very dirty, detach it and clean with a brush or vacuum cleaner.
- Blow through the appliance on the inside.
- If using propane, make sure the vent on the gas pressure governor is clean.

7. Malfunctions

Malfunctions may occur in the following areas:

- a) gas supply
- b) electrics
- c) regulation and control equipment

In case of a malfunction, please contact your local installer.

The most common malfunctions:

1. The ventilator will not run with the switch in any position.
2. The ventilator starts up in the "Heating" position but the solenoid valve doesn't open. (audible)
3. The ventilator starts up normally in the "Heating" position, the gas valve opens, but no flame forms.
4. The pilot burner stops burning.

Possible causes:

- a) The appliance is not connected to the mains.
 - b) The ventilator is blocked.
 - c) The ventilator motor or the starter capacitor is faulty.
 - d) The max. thermostat is switched off (reset) or defect.
-
- a) The air inlet opening is either completely or partially blocked.
 - b) The fan rotates too slow, because of a defect, pollution or bad electrical supply.
 - c) Defect on the vane switch.
 - d) Solenoid valve coil defect.
-
- a) The pilot burner is off.
 - b) The gas pressure is too low. Check the inlet pressure or remove dust.
 - d) Defect of the gas control.
-
- a) Flame too small; Turn the pilot burner adjustment screw clockwise (See page 8).
 - b) Inlet pressure too high.
 - c) Thermo couple defect or dirty.
 - d) Polluted pilot burner injector.

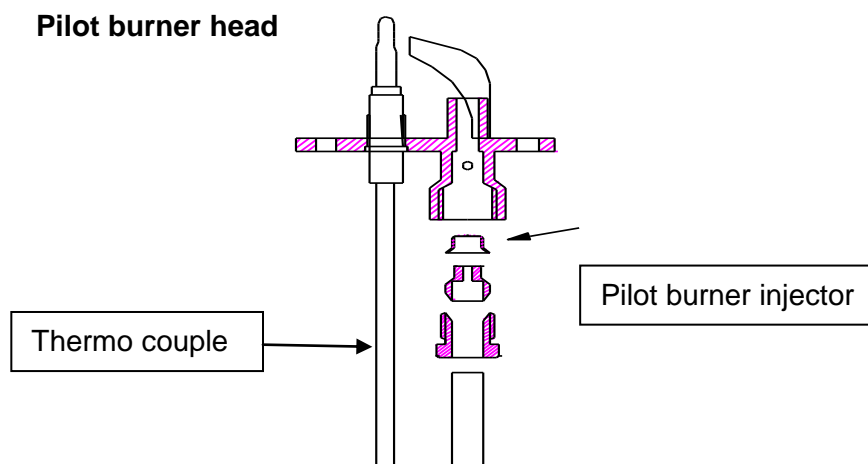

8.1. Diagram for ERA 33 parts list.

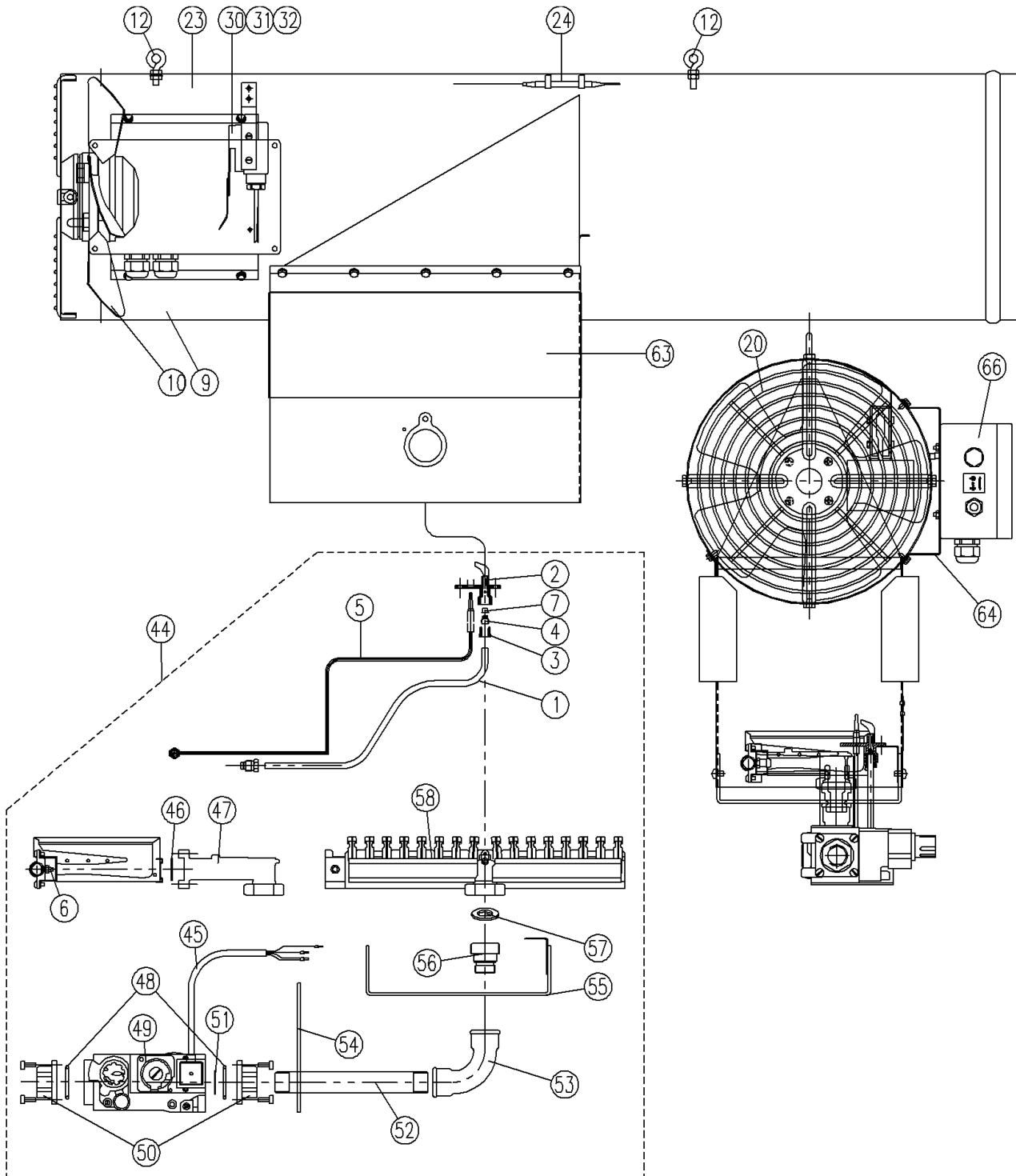

Note: Please quote the appliance number when ordering!

8.2. ERA 33 parts list

<u>Pos</u>	<u>Description</u>	<u>Code-No.</u>
1	Pilot burner conduit pipe 6x4	N50310004
2	Pilot burner head	N50280038
3	Included in pos 1	
4	Included in pos 1	
5	Thermo couple.....	N50290051
6	Natural gas: Injector (16x) ø1,25	N50310012
	Propane: Injector (16x) ø0,75	N50310014
7	Natural gas: Injector pilot flame	N50280042
	Propane: Injector pilot flame	N50280036
10	Ventilator EBM A2E250 115W	N50280064
12	M6 nut with lug	
20	Grille for ERA 33.....	N50280068
23	Mantle ERA 33	N50281013
24	Sensor TSLM max thermostat	
30	Air flow switch.....	N50390028
31	Bracket air flow switch	N50310034
32	Protective cap for micro switch	N50390030
44	Gas street ERA complete natural gas.....	N50310030
	Gas street ERA complete propane	N50310031
45	DIN Connector.....	N50310146
46	Gasket burner connector piece.....	N50311020
47	Burner connector piece ERA	N50311000
48	O-Ring ASW 4600	N50280024
49	Compact unit V4600A 1080B.....	N50310046
50	Flange (2x) for V4600, 1/2"	N50310155
51	Filter V4600	N50310150
52	Tube 1/2" x 160 GEG	N50310048
53	Angle 1/2" G nr.2	N50310047
54	Suspension strip gas street	N50310037
55	Bracket burner ERA.....	N50310021
56	Top connection	N50310020
57	O-ring	N50310019
58	Burner ERA Natural gas	N50310001
	Propane.....	N50310002
63	Burner house complete.....	N50310035
64	Bracket for switching cabinet	N50270014
66	Switch cabinet ERA 33 complete	N50310040

8.3. Diagram for switching cabinet parts list

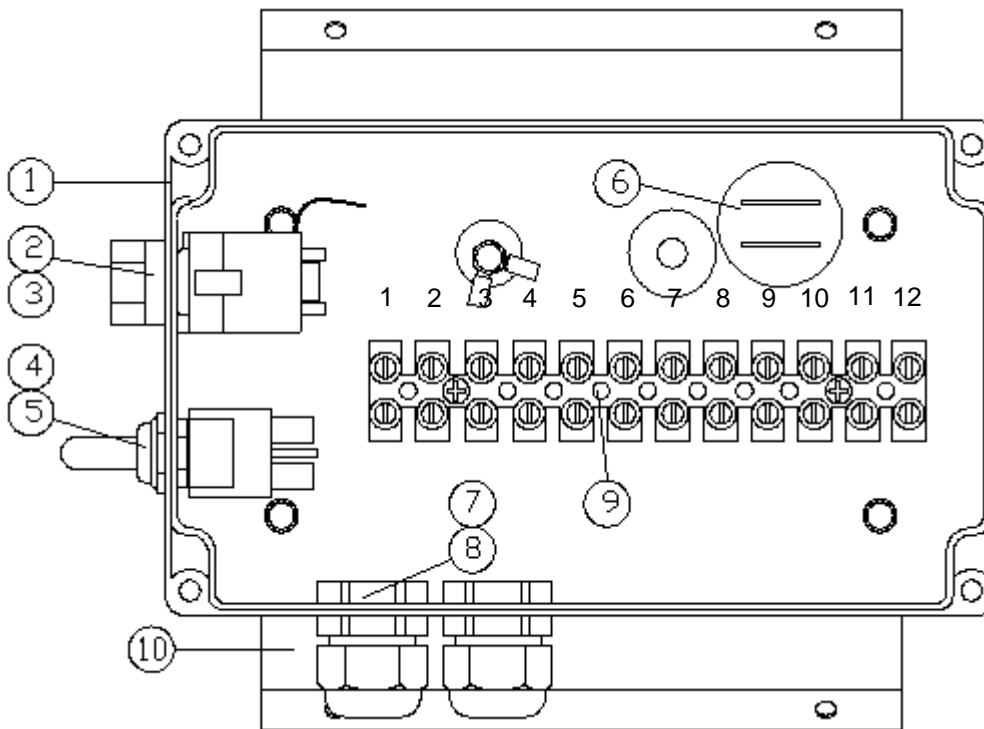

8.4. Part list witching cabinet

<u>Pos</u>	<u>Description</u>	<u>Code-No.</u>
1	Switching cabinet ERA 33 empty.....	N50310041
2	Thermostat max. temp.973.11227.01A-110°C.....	N50310070
3	Protective cap TSLM	
4	Two-pole switch.....	N50260033
5	Protective cap switch.....	N50310051
6	Capacitor 4µF/400 V.....	N50270012
7	Threaded joint PG9.....	N50270038
	Rubber O-ring PG9.....	N50270045
8	Nut PG9.....	N50270022
9	Terminal strip polyamide.....	N50260192
10	Mounting plate.....	N50270014

9. Appendices

9.1. Burner pressure table

30 kW nominal thermal load to be set in line with Wobbe-index*, burner pressure and injector diameter.

1. Gas family "N" Natural gases

Inlet pressure : 20 - 25 mbar

	Wobbe-index (kWh/ m ³)	Burner pressure (mbar)	Injector-ø [mm]
	11,65	15,9	16 x ø1,25
	11,90	15,2	16 x ø1,25
	12,15	14,6	16 x ø1,25
L-gas (kWh/m³)	12,40	14,0	16 x ø1,25
	12,65	13,5	16 x ø1,25
	12,90	12,9	16 x ø1,25
	13,25	14,4	16 x ø1,25
	13,50	13,9	16 x ø1,25
	13,75	13,4	16 x ø1,25
	14,00	12,9	16 x ø1,25
	14,25	12,4	16 x ø1,25
	14,50	12,0	16 x ø1,25
	14,75	11,6	16 x ø1,25
H-gas (kWh/m³)	15,00	11,2	16 x ø1,25
	15,25	10,9	16 x ø1,25
	15,50	10,5	16 x ø1,25

2. Gas family "F" Liquid gases/propane

Inlet pressure : 50 mbar

Burner pressure : 29 mbar

Injector diameter : 16 x 0,75 mm

* The nozzle pressure figures apply at 15°C plus 1.013 mbar atmospheric pressure and with dry gas. The Wobbe index is the quotient of the gross calorific value (Ho) and the root of the relative density (d).

$$\text{Wobbe-index} = \frac{H_o}{\sqrt{d}}$$

9.2. ERA 33 circuit diagram

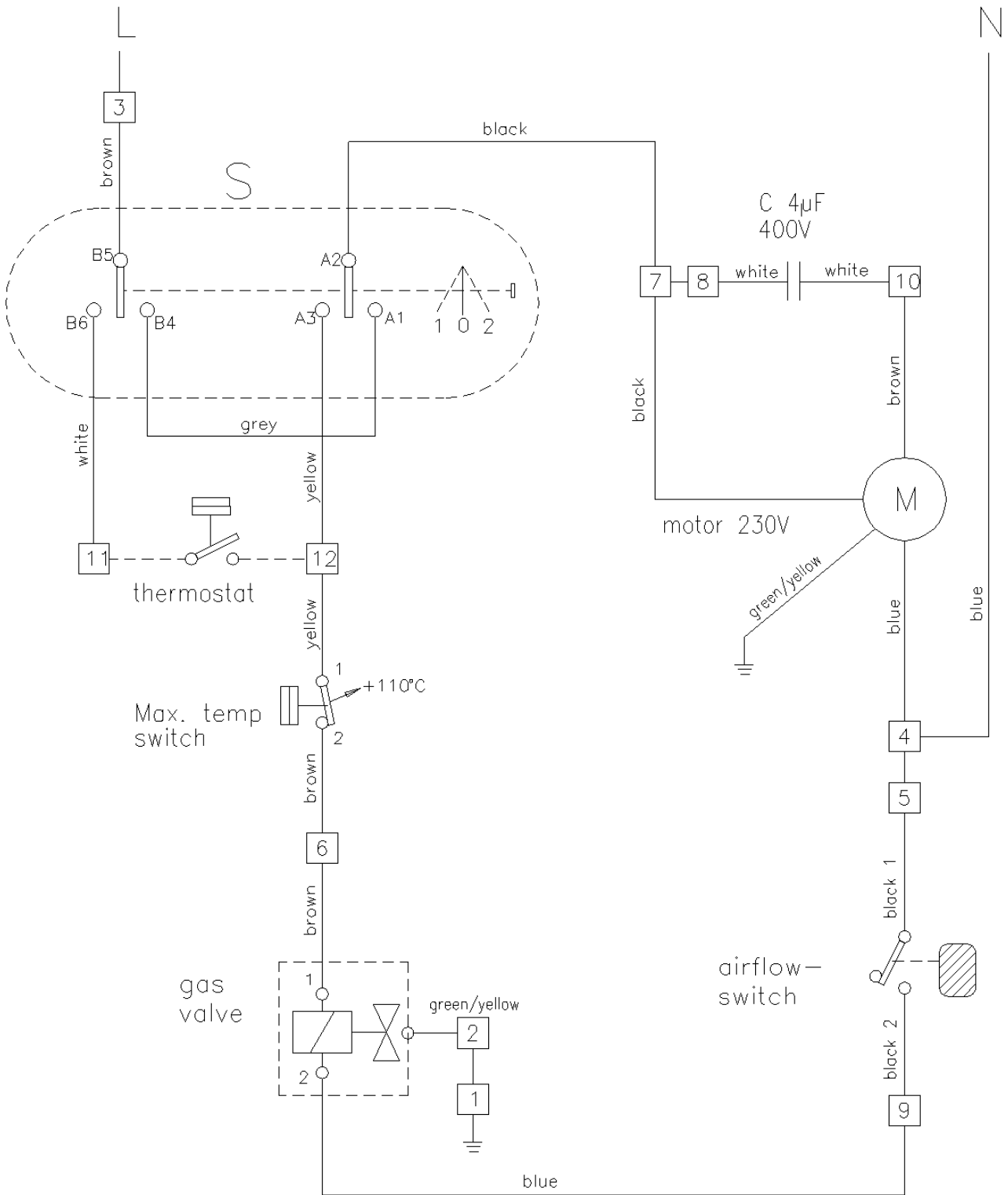

ERA 33 231003

9.3. Gas connection diagram

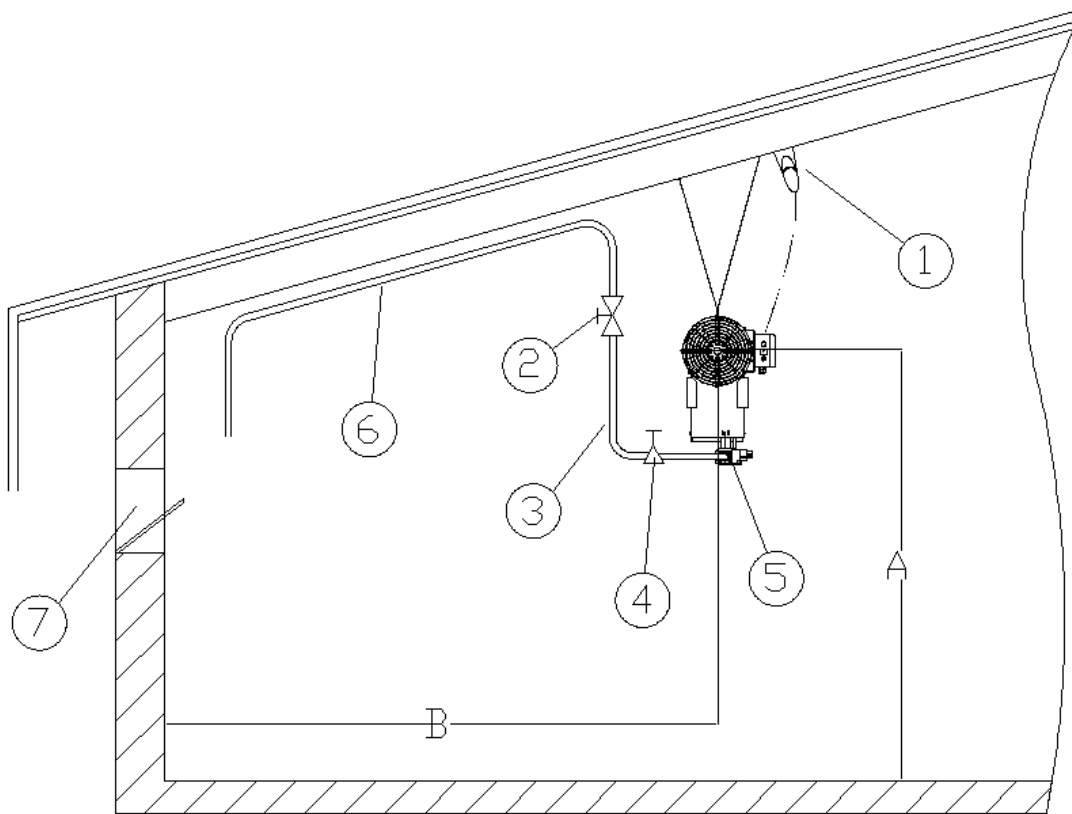

A = height \pm 1.8 m; please match to height of air intake vents
 B = 2 - 2.5 m; please note distance to feeding and drinking equipment

<u>No.</u>	<u>Code nr.</u>	<u>Description</u>
1.		Mains socket (always disconnect from mains when carrying out servicing and maintenance work!)
2.	N50280057	230 V cable with mains plug
3.	N52600019	1/2" manual gas valve to DVGW standard
4.	N52600049	1/2" gas hose 1,5 mtr.
5.	N52600023	Pressure regulator: for propane use: 1,4 bar > 50 mbar
6.		Gas inlet connection. Note inlet pressure: Natural gas: 20 – 25 mbar, Propane: 50 mbar.
7.		Gas main
		Air intake vent

9.4. Return of goods form

User name : _____
 Address : _____
 Telephone number : _____
 E-mail address : _____
 Returned by; Mr./Mrs. : _____
 Date : _____

Description of returned goods	
Quantity	
Type and serial nr. heater	
Power supply	Volt / Hz
Inlet gas pressure	mbar
Burner gas pressure	mbar
Reason for return	
Description of failure	
Requested action	Credit / Exchange / Repair
Remarks	

Please return the goods to your nearest Dealer

9.5 Contact

For technical questions contact your local Ermaf dealer or the Ermaf competence center:

Elster-Instromet B.V.
 Munstermanstraat 6
 7064 KA Silvolde
 the Netherlands
 T +31 315 338 911
 F +31 315 338 679

elster
 Kromschröder

Elster-Instromet B.V.
 Sales office
 P.O. box 2809, 49018 Osnabrück
 Strohteweg 1, 49504 Lotte (Büren)
 Germany
 T +49 541 1214 702
 F +49 541 1214 506
 orders.ermaf@elster.com
 www.ermaf.nl